



Data-Driven Discoveries in Spatial Analysis of Urban Mobility Networks

Ronghui Liu
Professor of Networks and Transport Operations
Institute for Transport Studies (ITS)
University of Leeds
R.Liu@its.leeds.ac.uk



A brief overview – Methodologies and applications

Urban morphology

- Grid, circular, loops/lollipops
- Fine-, coarse-grained
- Planned vs self-organised

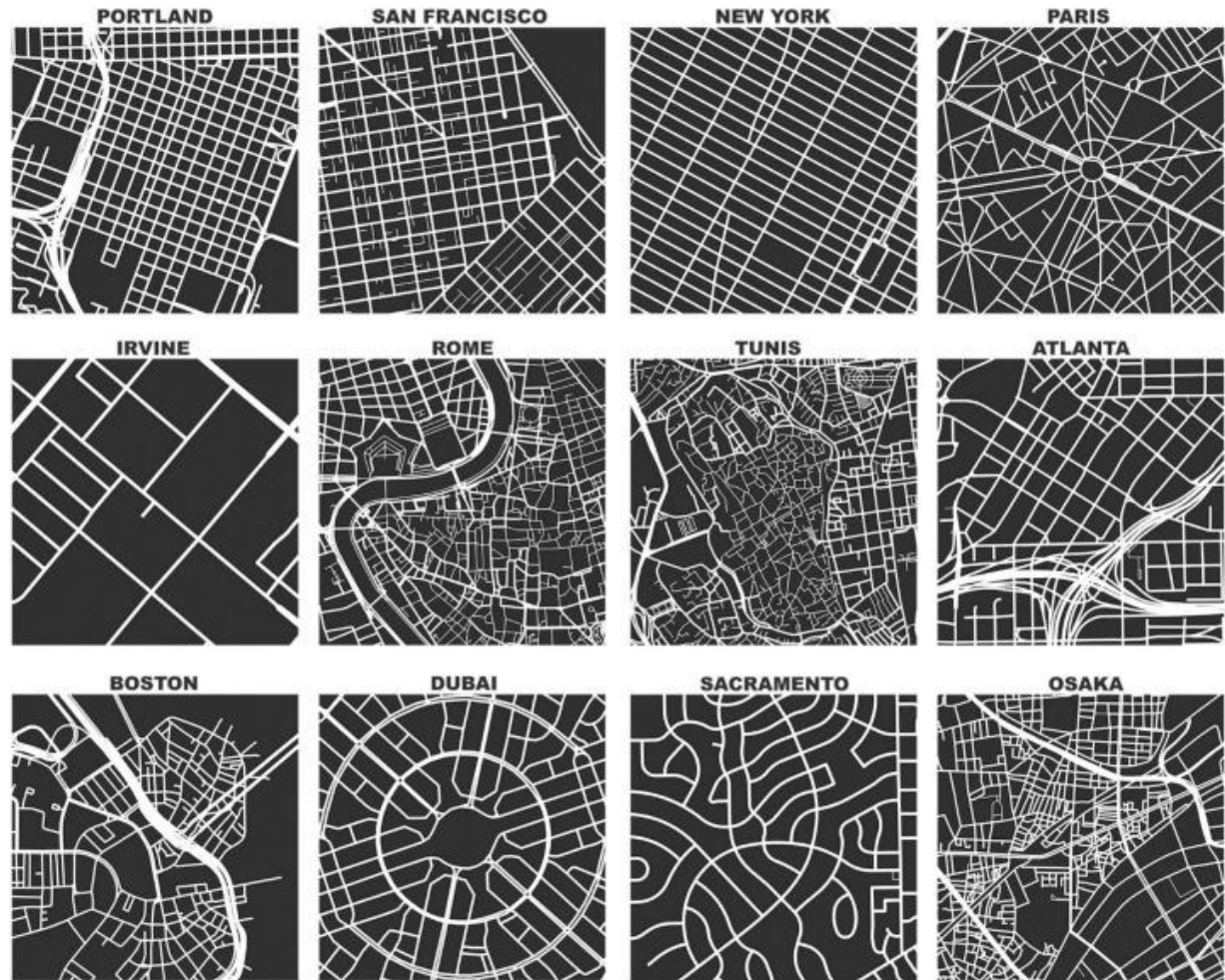

Evolution of spatial analysis in urban mobility

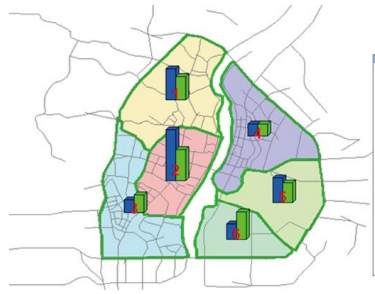

Aggregate thinking

Non-aggregate thinking



Model-driven

Data-drive

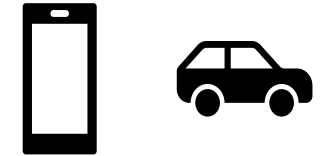

Understanding of pattern and processes

Prediction, control, and management

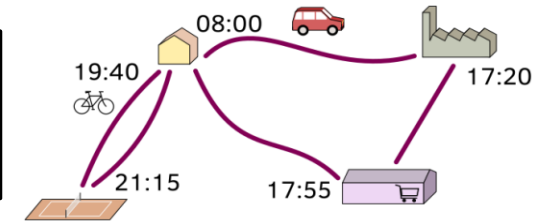

Traditional techniques

- Manually collected data
 - Travel diary
 - Questionnaire
 - Travel survey
 - ...

Expensive, Static, Small-sample

Item	Coding and comments
Day of trip	Days of the week
Starting time	Military time
Purpose	Work, education, daily shopping, shopping for major items, personal business, work related business, leisure (please specify), other (please specify)
Modes used	Walk only, walk to mode; bicycle, motorcycle, car driver, car passenger, bus, street car and light rail, heavy rail, other (please specify), walk from mode; time spent on each
Accompanying persons	Number of household members, number of other persons
Presence of a dog	Yes, no
Exact destination	Street address and municipality
Activity costs	Zero, up to 10 DM, 10–25 DM, 25–100 DM, 100 DM and over
Expenditures on travel	Open
Arrival time	Military time
Estimated distance travelled	[m]

The screenshot shows a complex form titled 'COMPLETE FOR ALL TRIPS THAT INCLUDE CYCLING ON CYCLE TRAVEL DAYS'. It includes sections for origin and destination addresses, trip purpose, modes used, and a detailed list of activities with checkboxes for each. At the bottom, there is a section for 'FULL INTERCHANGE DETAILS' with columns for trip number, time, and location.

Category / variable	Items	Questions
Public transportation privacy (PTP)	PTP1	In public transportation people sometimes come too close to me in an unpleasant manner.
	PTP2	In public transportation my privacy is restricted in an unpleasant manner.
	PTA1	I can structure my everyday life very well without a car.
	PTA2	I can take care of what I want to with public transportation.
Public transportation autonomy (PTA)	PTA3	It is difficult for me to travel the ways I need to go in everyday life with public transportation instead of by car.
	PTA4	If I want, it is easy for me to use public transportation instead of a car to do my things in everyday life.
	PTE1	I appreciate public transportation, because there is usually something interesting to see there.
	PTE2	I can easily use the traveling time on the bus or train for other things.
Public transportation excitement (PTE)	PTE3	I like to ride buses and trains, because I don't have to concentrate on traffic while doing so.
	PTE4	I can relax well in public transportation.
	PTI1	It is my intention to use public transportation instead of a car for the things I do in everyday life.
	PTI2	I have resolved to travel the ways I need to go in everyday life using buses and trains.
Public transportation intention (PTI)	SN1	People who are important to me think it is good if I would use public transportation instead of a car for things I do in everyday life.
	SN2	People who are important to me think that I should use public transportation instead of a car.
Subjective norm (SN)	PN1	Due to my principles, I feel personally obligated to use eco-friendly means of transportation for the things I do in everyday life.
	PN2	I feel obligated to make a contribution to climate protection via my choice of transportation.
Personal norm (PN)	CE1	Driving a car means fun and passion for me.
	CE2	Driving a car means freedom to me.
	CE3	When I sit in the car I feel safe and protected.
	CE4	Being able to use my driving skill when driving a car is fun for me.
Car excitement (CE)	PMN1	My everyday organization requires a high degree of mobility.
	PMN2	I constantly have to be mobile in order to comply with my everyday obligations.
Perceived mobility necessities (PMN)	BE1	I like to be out and about by bike.
	BE2	I can relax well when riding a bike.
Bicycle excitement (BE)	BE3	I ride a bicycle because I enjoy the exercise.
	WR1	I don't like to ride my bike when the weather is cool.
	WR2	I also ride my bike when the weather is bad.
Weather resistance (WR)		

Axhausen, et al , 2002. Observing the rhythms of daily life: A six-week travel diary. *Transportation*, 29(2), pp.95-124.

von Behren, et al , 2018, January. Bringing travel behavior and attitudes together: An integrated survey approach for clustering urban mobility types. In *TRB 97th Annual Meeting Compendium of Papers, Washington, DC*.

Fairnie et al 2016. Active travel in London: the role of travel survey data in describing population physical activity. *Journal of Transport & Health*, 3(2), pp.161-172.

Traditional techniques

- **Descriptive Statistics**

- Basic statistical measures (mean, median, mode)
- Visual representation of data (graphs, charts)
- Applications in summarising travel behaviours

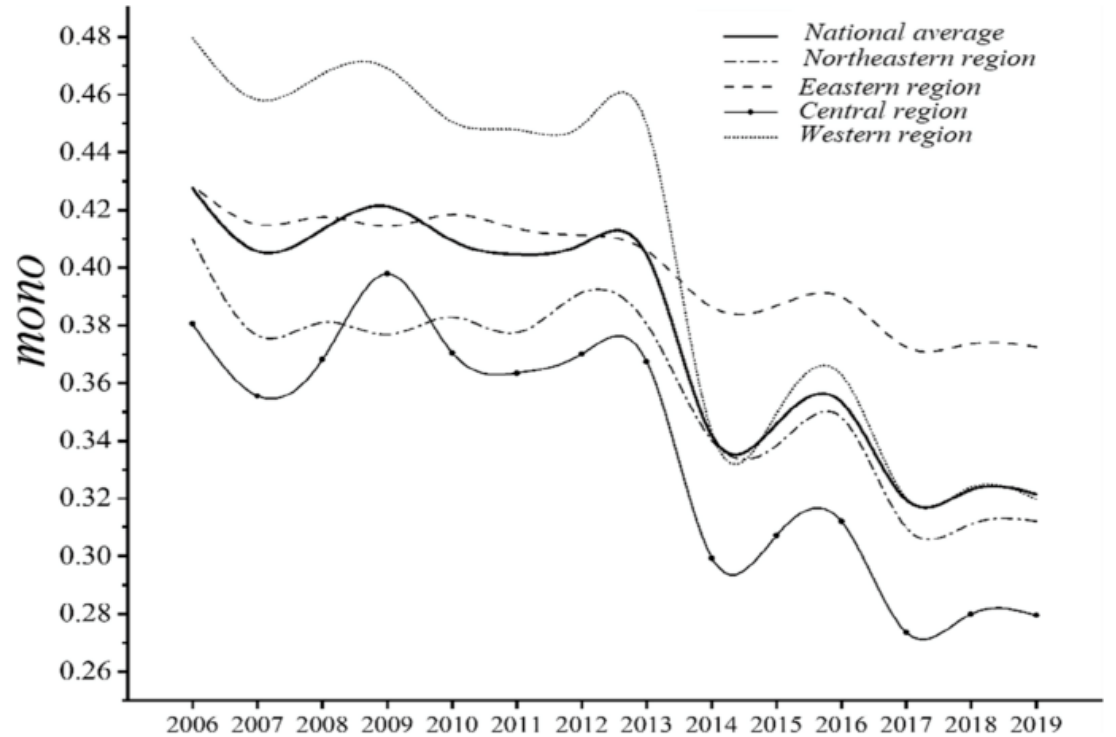

Figure 1 The temporal changes of the urban spatial structure in four regions of China

Emerging techniques

Big data sources

- Sensor, passive data
- Integration of technology in data collection and analysis



Emerging techniques

- **Geographic Information Systems (GIS)**

- Integrating spatial and non-spatial data
- Visualising spatial patterns of mobility

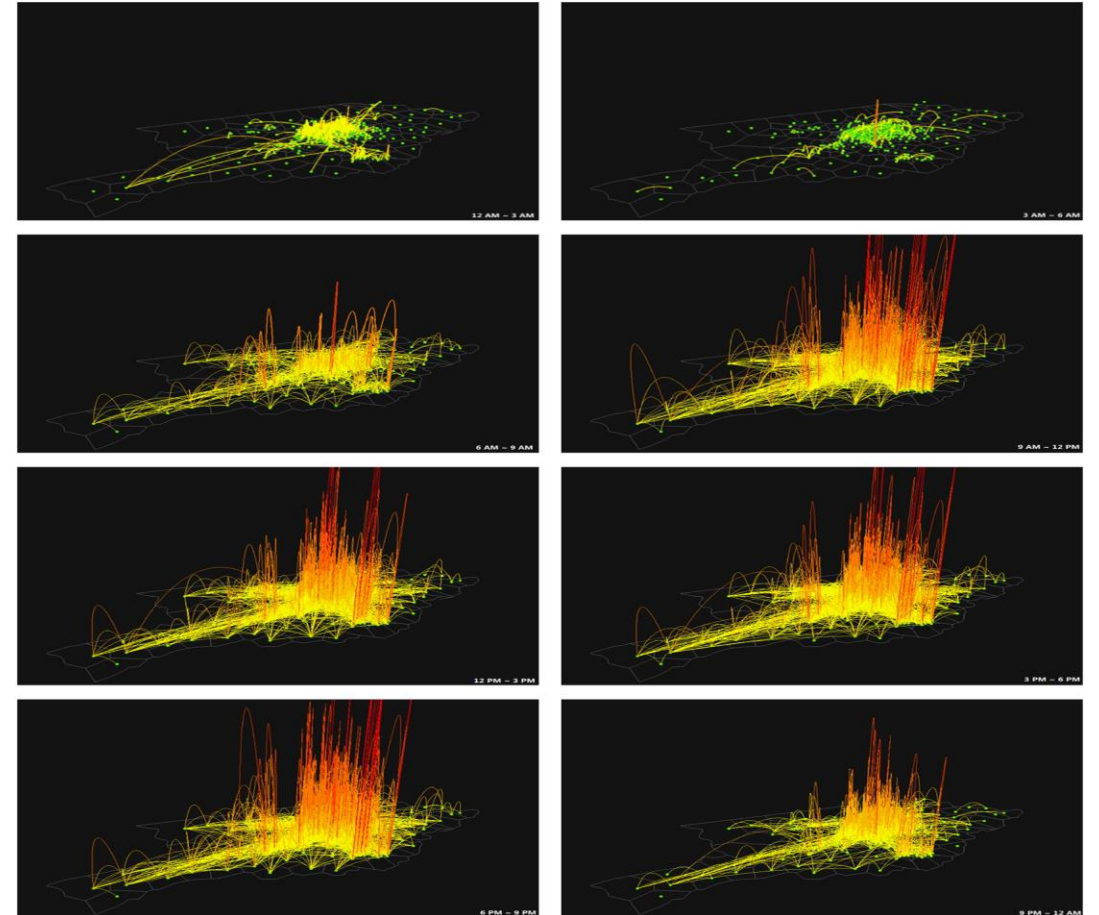

3D visualization of hourly phone-call flow patterns across cells in a day

Emerging techniques

- **Advanced Network Theory**

- Understanding the complex interactions and dependencies within urban transport systems
- Designing transit systems that serve different neighbourhoods effectively, ensuring balanced accessibility

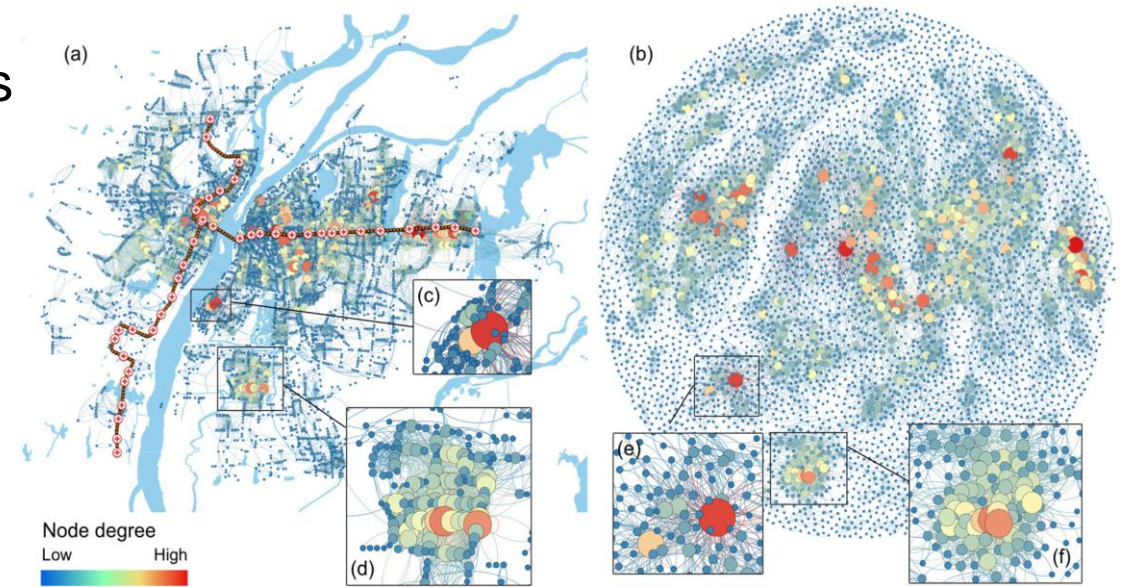

Dockless bike travel flows and graph structure of “before period” in (a) spatial layout; (b) Fruchterman Reingold layout, with detail in (c) to (f) as described in the text.

Applications Overview

Networks

Metro
Bus
Road
Travel

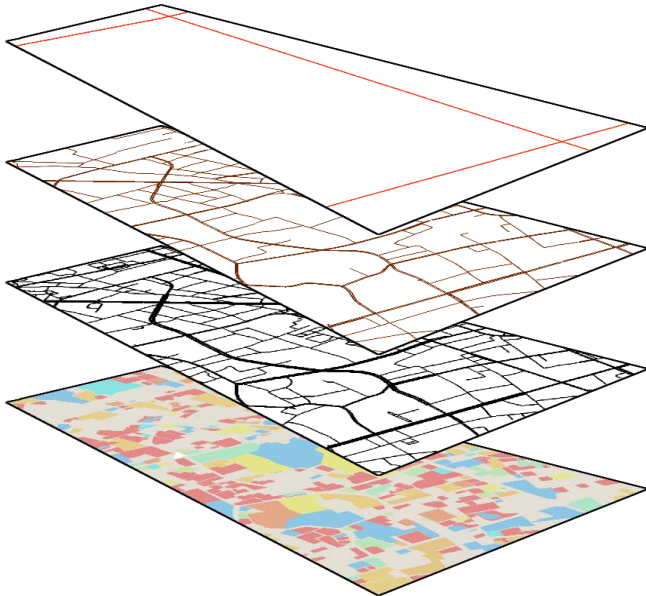

Focus

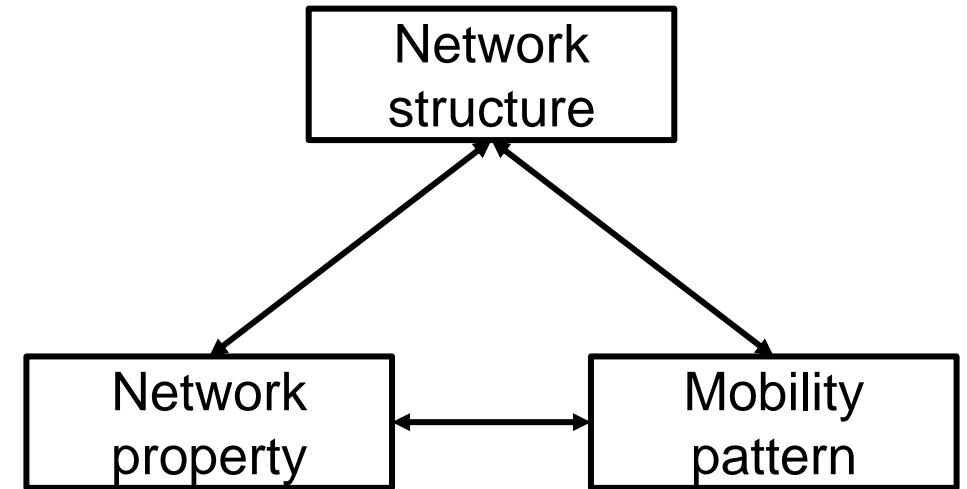

Bus infrastructure network

- Utilisation of complex networks in statistical physics to investigate bus systems.
- Construction of weighted **bus line** network and weighted **bus station** network for the city of Hohhot.
- Discovery of dense networks and linear distributions.
- Observation of a large average degree indicating densely distributed bus stops.
- Large clustering coefficient suggesting frequent overlap of bus routes.
- Small average shortest path length, indicating efficient routes with fewer transfers for citizens.

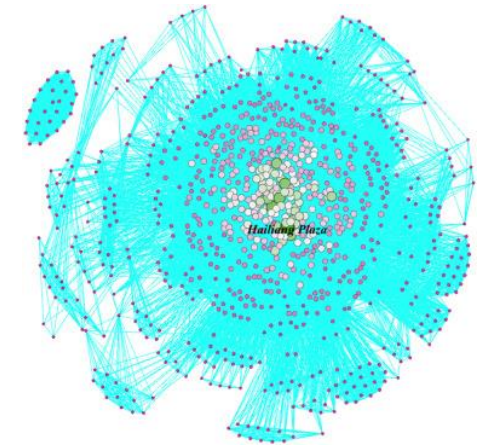

Bus-station-network

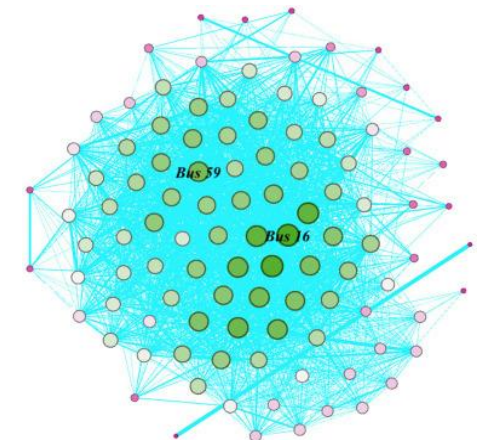

Bus-line-network

Road network resilience

- Road networks include motorways, dual carriageways, national, conventional and local roads
- The resilience analysis includes:
 - The definition of the sequence of section elimination
 - The generation of scenarios throughout the cumulative elimination of sections
 - The calculation of loss-of-accessibility
- The capacity of different road networks to withstand, self-organise and react to severe conditions
- Detecting key thresholds corresponding to irreversible collapses, and as a support system for designing and planning transport policy

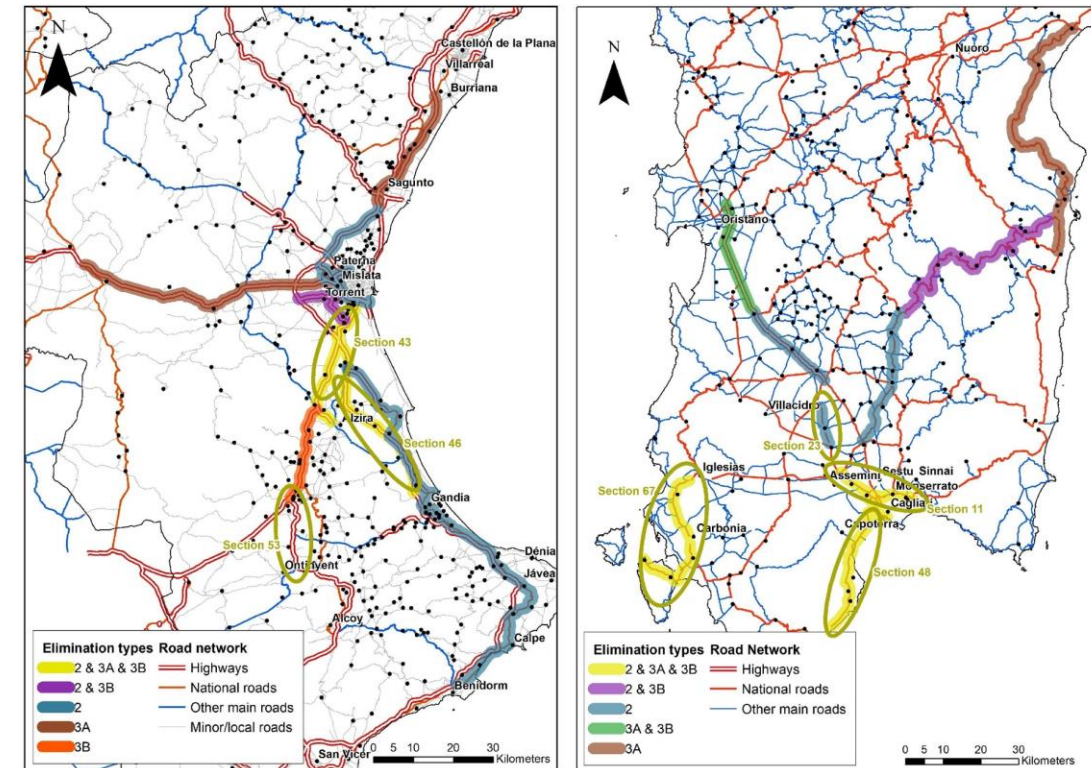

Spatial analysis of the most critical road sections (in the highest decile of associated loss of accessibility) by ET in Valencia (left) and Sardinia (right).

Traffic congestion

- Velocities of more than 1,000 roads with 5-min segments records measured in a road network in a central area of Beijing
- Percolation theory approach: a threshold for road connection
- A giant cluster of local flows disintegrates as critical bottlenecks become congested
- Bottlenecks that affect global traffic evolve throughout the day based on traffic dynamics

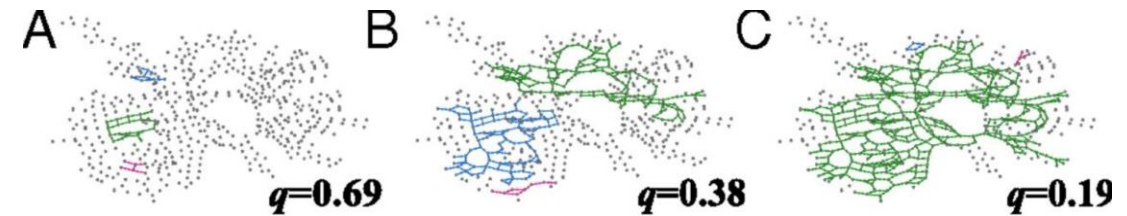

The traffic networks under the states of high-, medium-, and low-velocity thresholds, respectively. For clarity, only the largest three clusters are plotted,

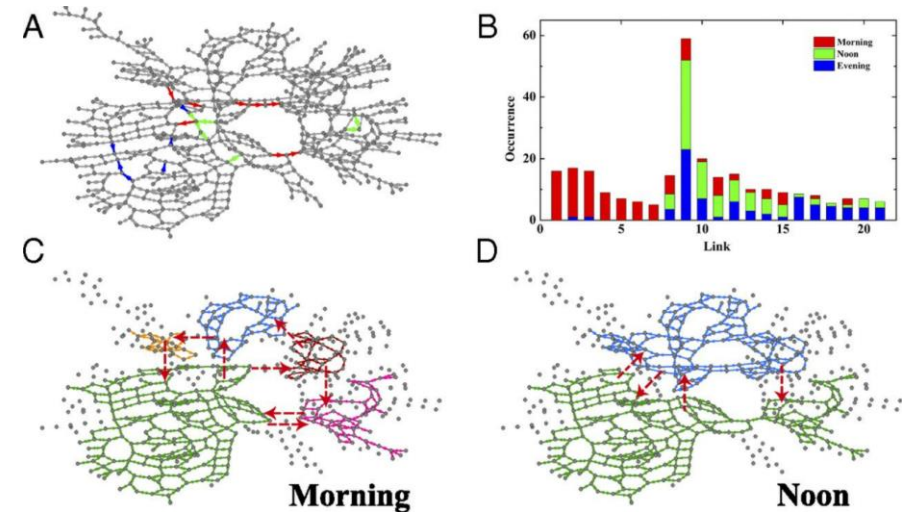

Evolving bottlenecks in different periods

Urban mobility analysis

- Analysis of mobility patterns using anonymised mobile phone data.
- Measurement of entropy to determine predictability in individual trajectories.
- 93% potential predictability in user mobility across the entire user base.
- Despite varying travel patterns, predictability remains remarkably consistent.
- Predictability is largely independent of the distance users regularly travel.

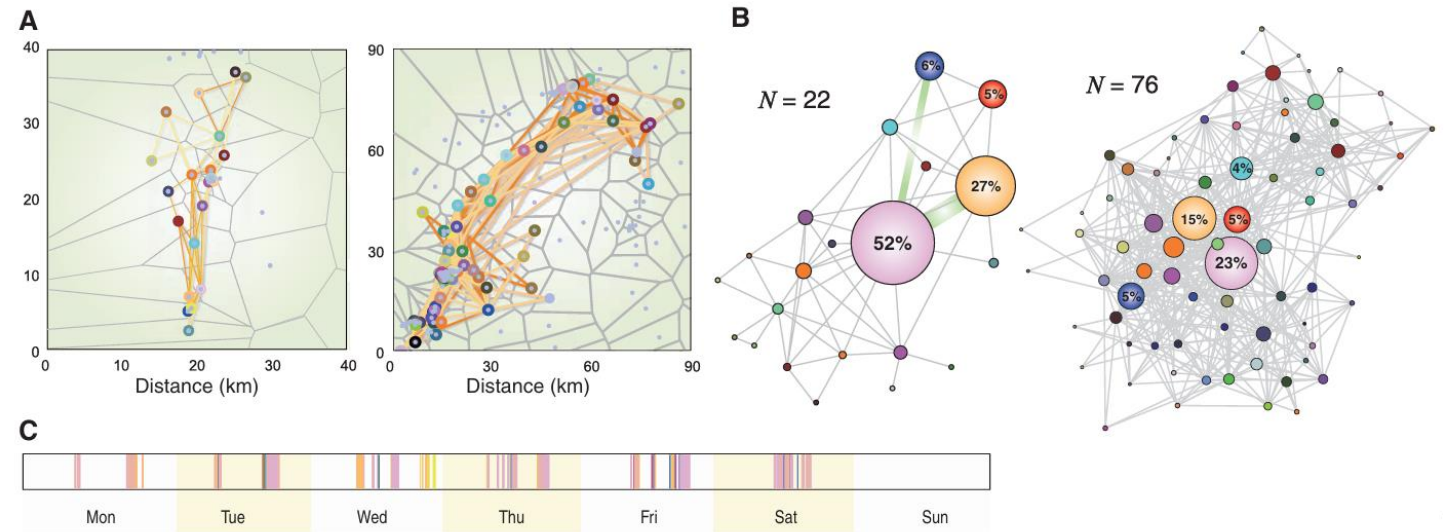

A: Visualisation of two users' movements between mobile phone towers.

B: Network representation showing the frequency of calls and movements between towers for the two users.

C: Time-dependent location data of a user over a week, used for mobility prediction.

Interplay between demand and supply

- Tram network: Stop-level passenger flow and line-stop network
- Some indicators in space-of-infrastructure network match the flow distribution pattern

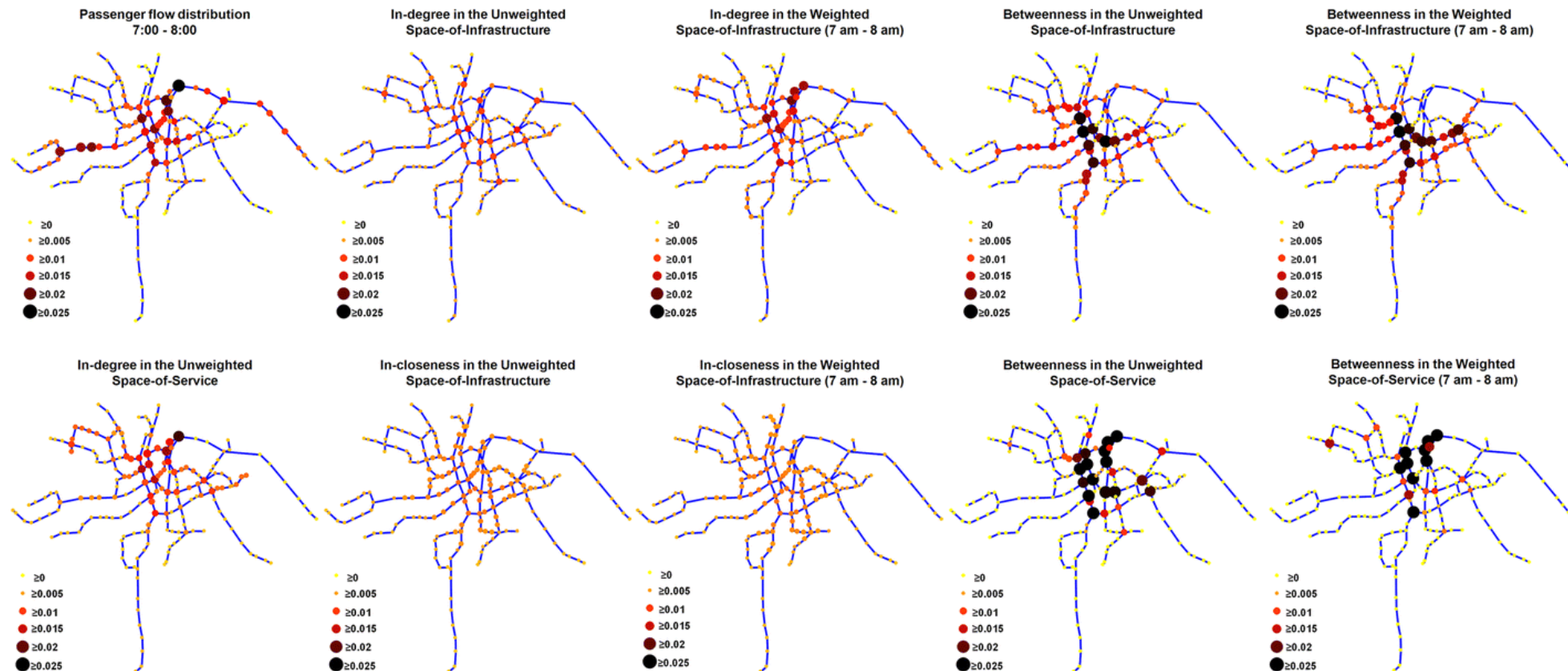

Visualization of the passenger flow distribution and the employed centrality indicators for the weekday morning peak (7 a.m.–8 a.m.) of the tram network of Amsterdam

Some of our own analyses

Public transport mobility analysis

- Smart-card data for daily mobility pattern
- Focusing on zone-base Origin-Destination only, ignoring line connections
- Studying the spatio-temporal properties of networks by clustering, correlation measures, etc.

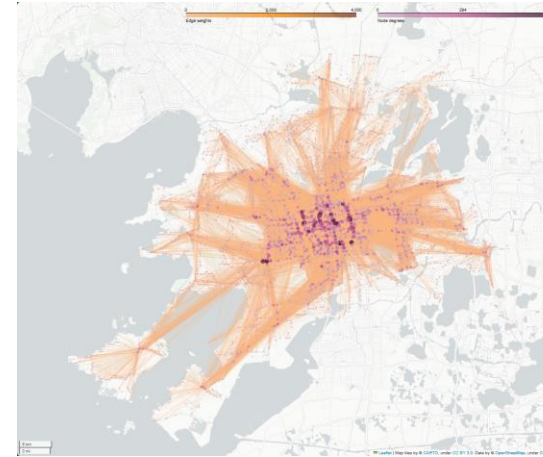

Bus mobility network

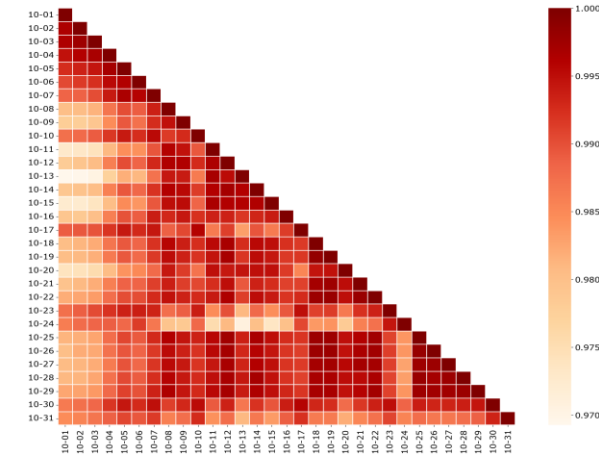

Temporal analysis

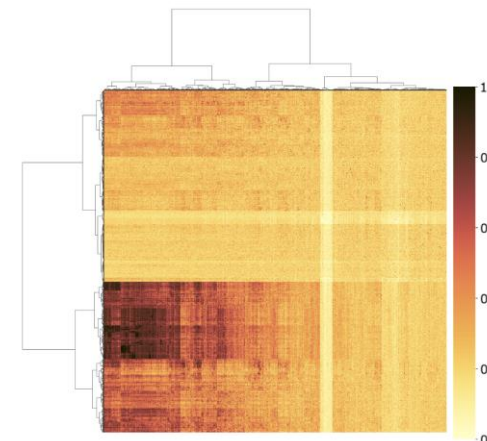

Spatial analysis

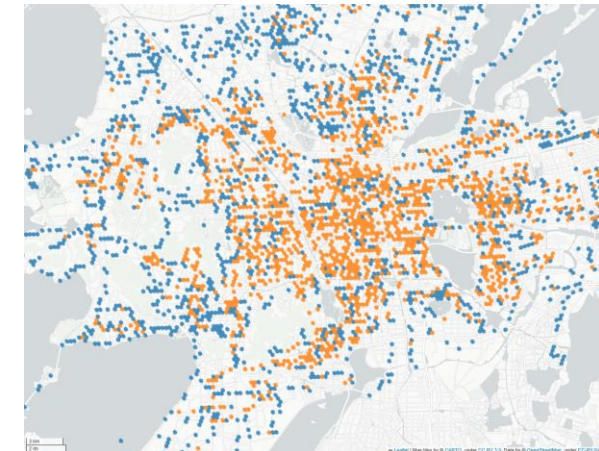

Spatial pattern

Bus mobility prediction

- Bus routes limit bus mobility, leading to transferring
- Heterogeneous topologies for direct and transfer trip
 - Bus-line connectivity: not a real OD
 - Fully-connected network: lost boarding and alighting behaviours
- Challenging current mainstream methodologies
 - Spatio-temporal convolutional networks
 - Homogeneous graph (fixed adjacency matrix)

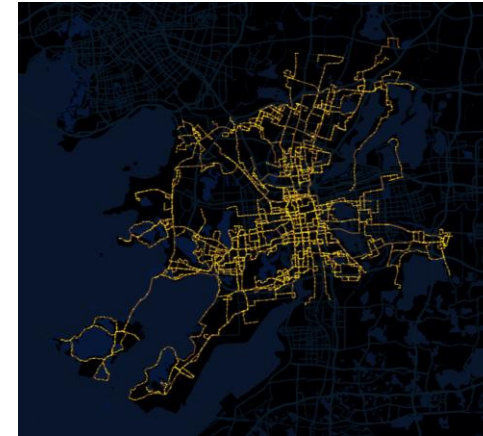

Bus lines

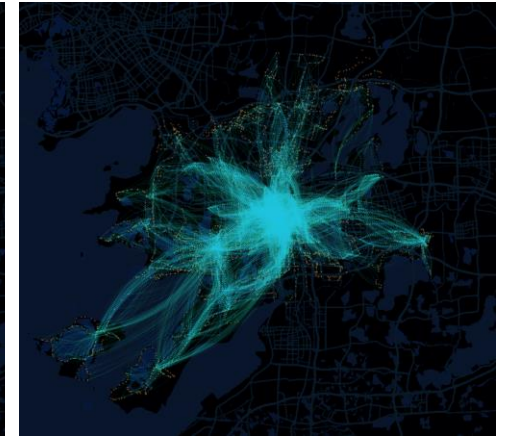

Bus mobility network

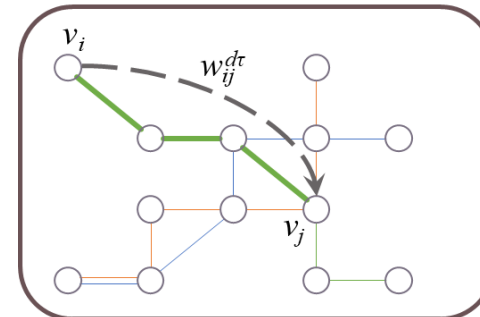

Direct trip network

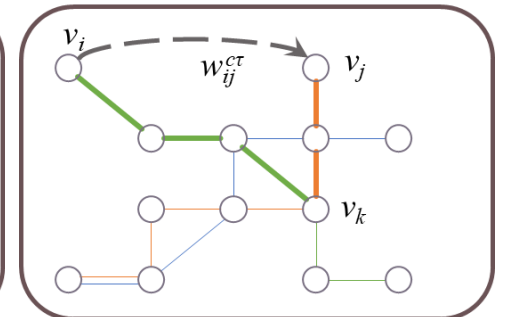

Transfer trip network

Bus mobility prediction

- **Direct-Transfer Heterogeneous Graph Network**
 - Capturing spatio-temporal patterns of bus mobility (ST-block)
 - Embedding topology of bus line network (AE-block)
- Outperforming state-of-the-art models
 - Large absolute errors are infrequently distributed
 - Direct trips: city centre - positive errors, suburban - negative errors.
 - Transfer trips: minimal for all time slots

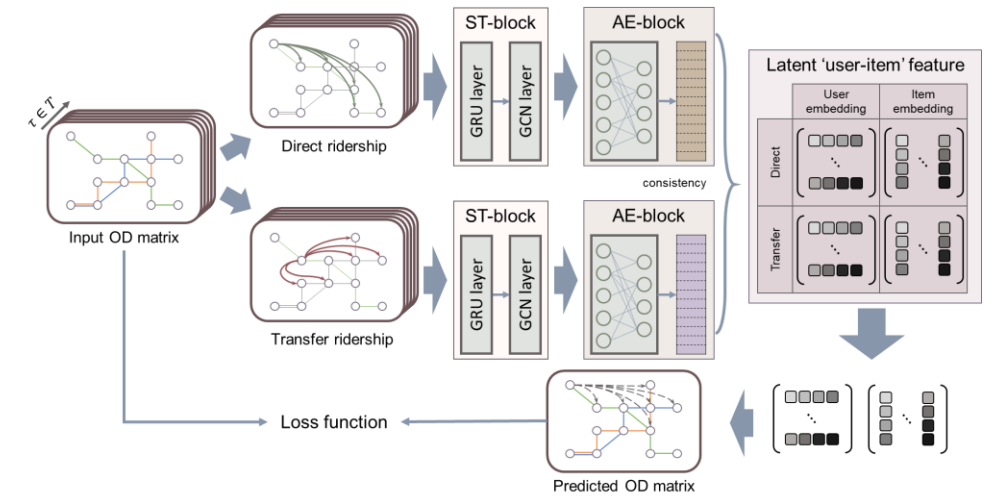

Model architecture

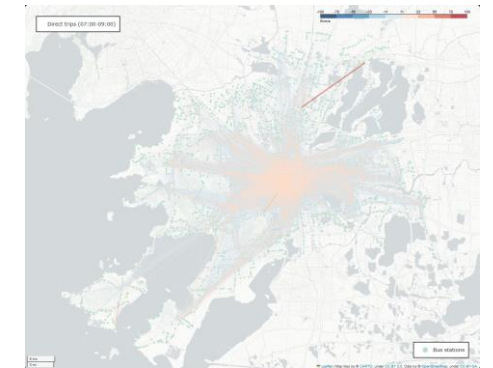
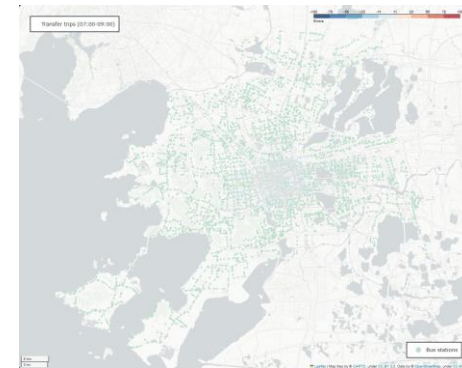

Prediction errors in the morning peak

Metro mobility prediction

- Metro demand includes:
 - Inbound flow
 - Outbound flow
 - Inbound OD matrix
 - Outbound OD matrix
- Challenges:
 - Partial observability problem of the inbound OD matrix
 - Interactions among four types of demands

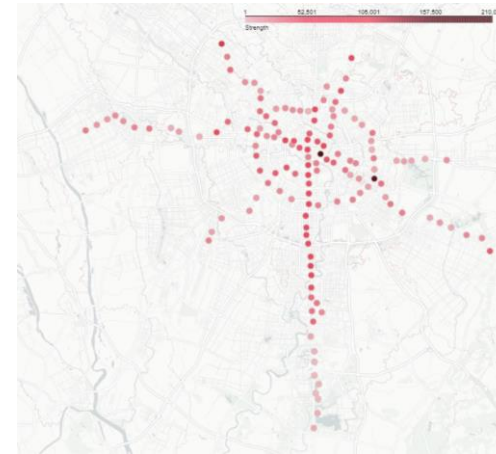

Metro mobility

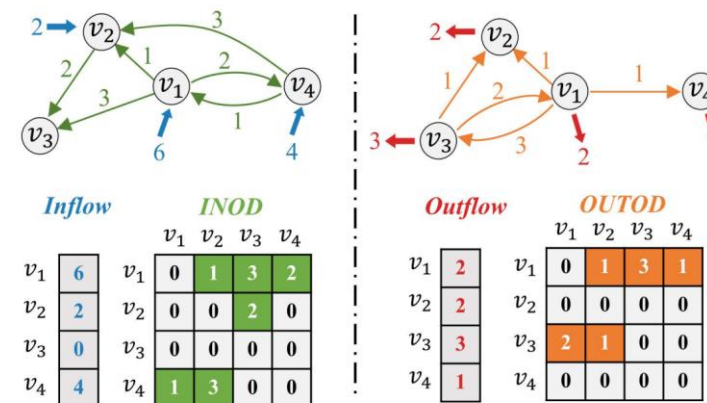

Multiple demand for metro

Metro mobility prediction

- Deep multi-task learning model for metro passenger demands prediction
 - Deploying the message-passing schemes to capture the inherent relationships among multiple demands
 - Adapting DWA scheme to balance the training of multiple tasks

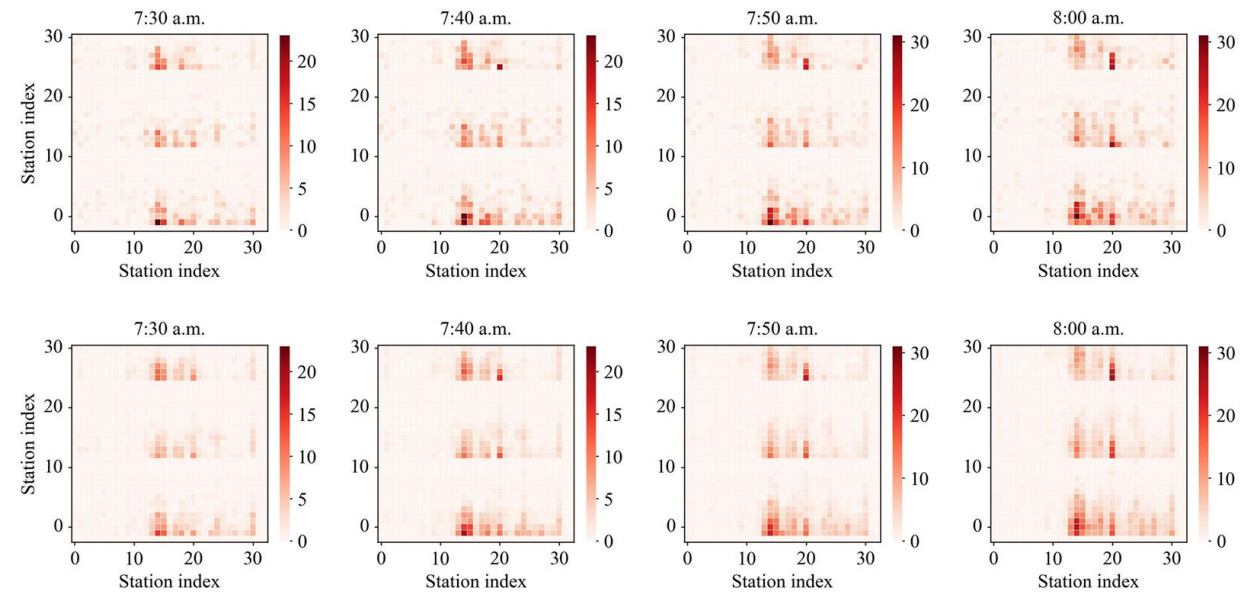
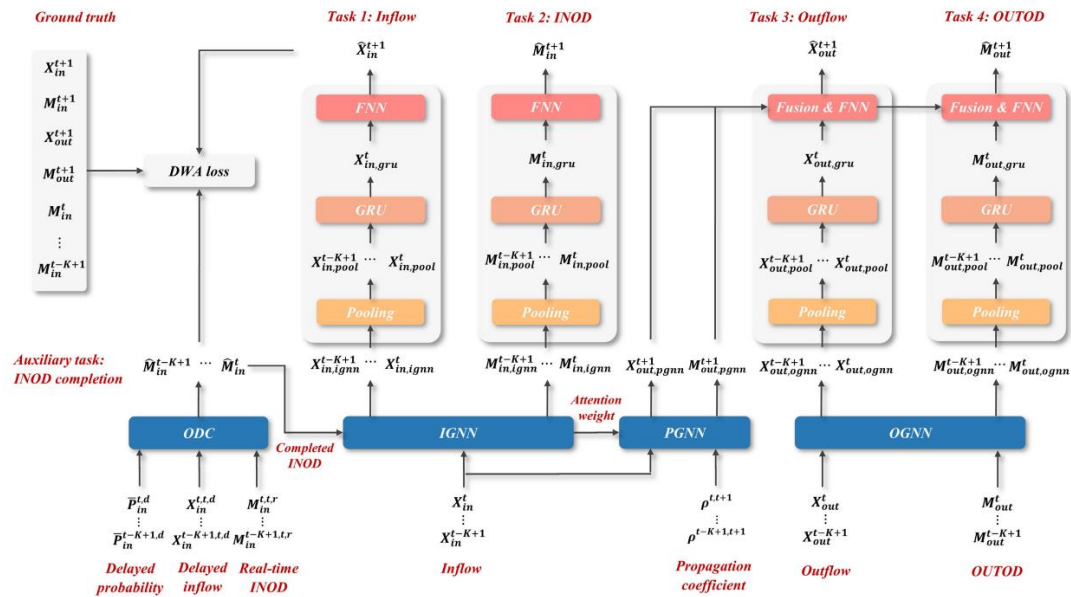

Framework of the proposed MTLMetro

Ground truth (top) and prediction results (bottom) on the INOD

Summary

- Advancements in spatial analysis
 - The integration of data-driven methodologies has significantly advanced our understanding of urban mobility patterns.
 - These advancements support efficient and sustainable urban planning and infrastructure management.
- Innovative methodologies
 - Cutting-edge techniques, such as GIS, network theory, and AI, have transformed spatial analysis
 - These methodologies provide deeper insights into urban transport systems and mobility patterns.
- Case studies in data-driven analysis of urban mobility:
 - Individual road vehicle movements => congestion patterns
 - Bus network studies => route efficiency and service accessibility
 - Urban metro infrastructure => passenger flow, station connection, network resilience
 - Mobility movements => infrastructure improvements

Challenges and opportunities

- Data quality and accessibility
 - Inconsistent data
 - Data privacy
 - Limited accessibility
- Methodology
 - Complexity
 - Scalability
- Emerging transport modes
 - Multimodal transport
 - Autonomous vehicles
- Interdisciplinary approaches
 - Theory transfer and applications
 - New complementary data



Thank you!
(r.liu@its.leeds.ac.uk)

